





# ARROW P

ARP

INSTRUKCJA MONTAŻU  
ASSEMBLY INSTRUCTIONS  
INSTALLATIONSANWEISUNGEN  
INSTRUCTIONS D'INSTALLATION  
INSTRUCCIONES DE INSTALACIÓN  
ISTRUZIONI PER L'INSTALLAZIONE

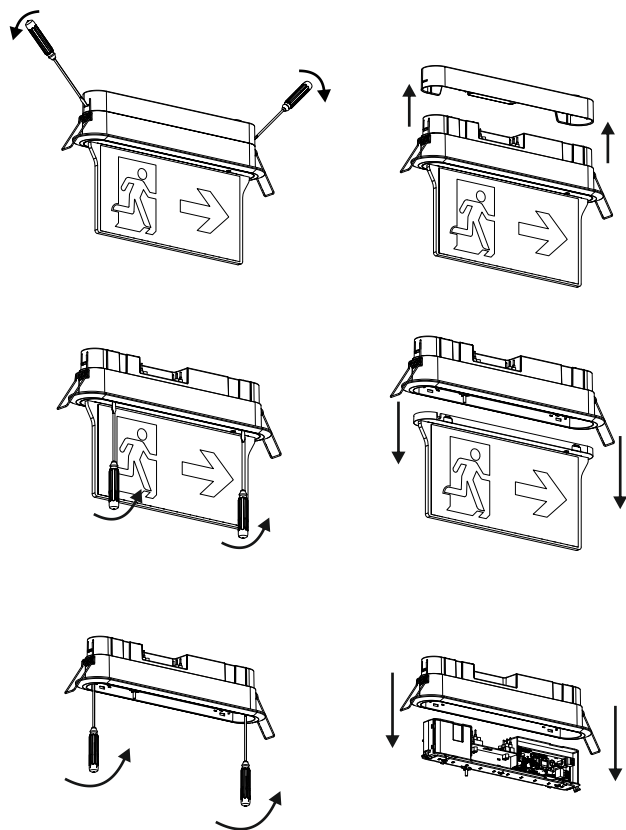
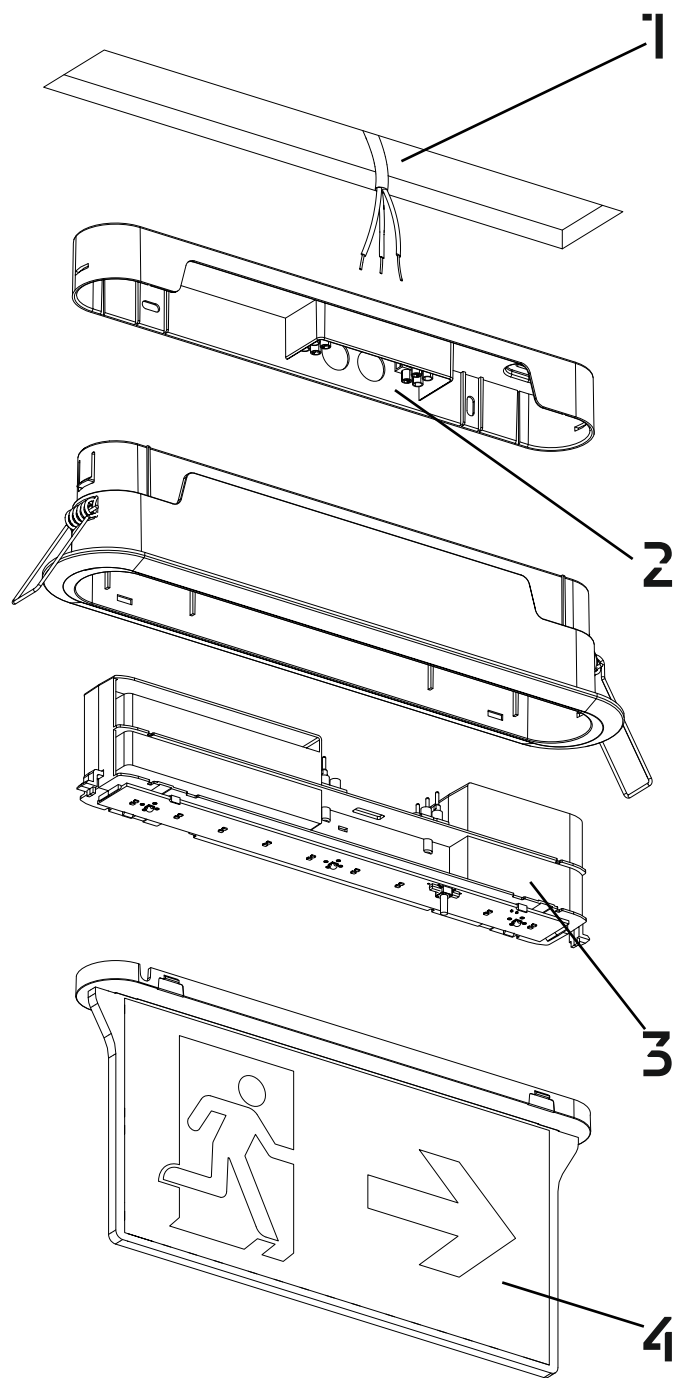
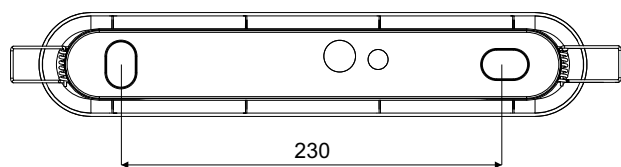
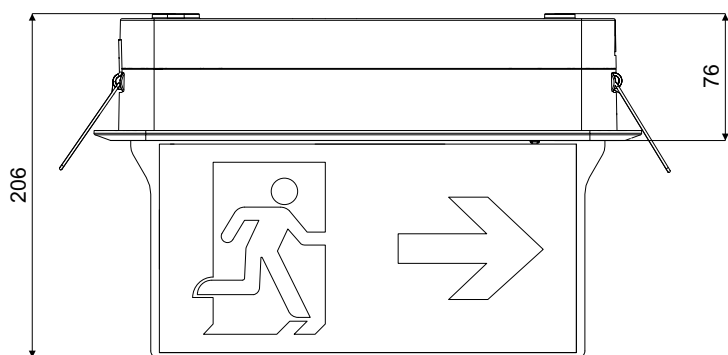
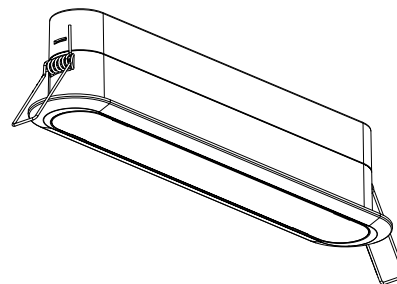
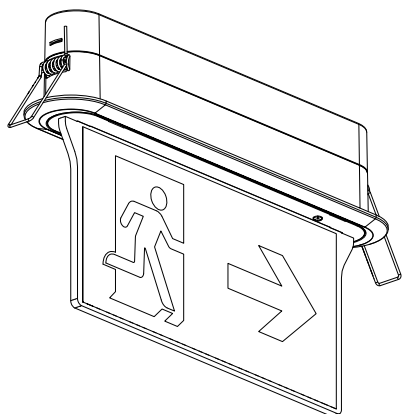

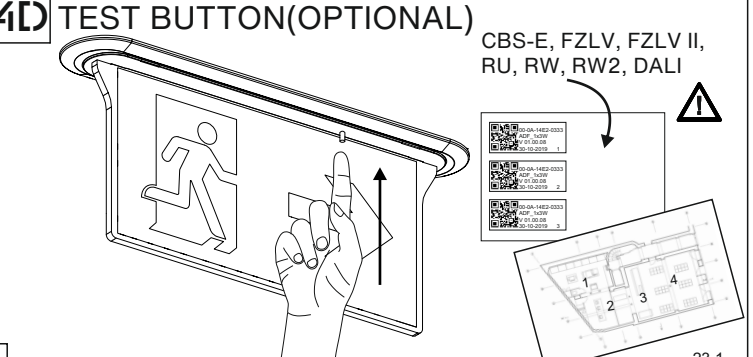
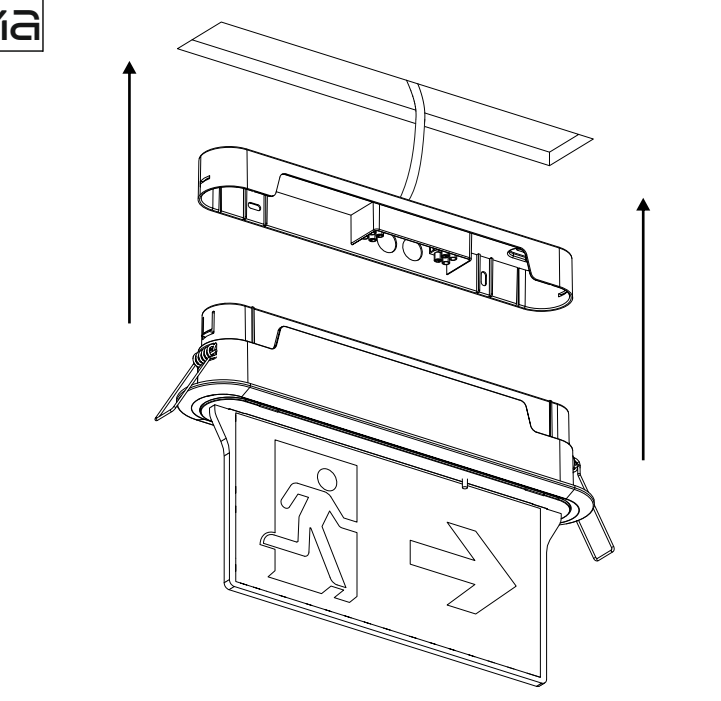
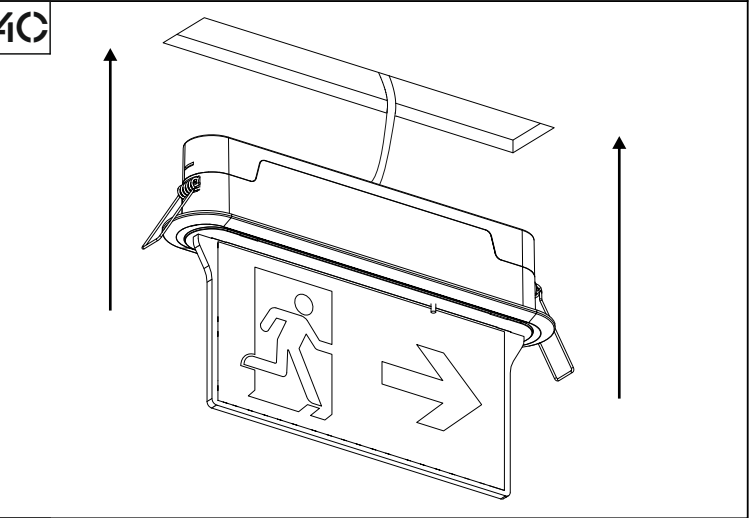
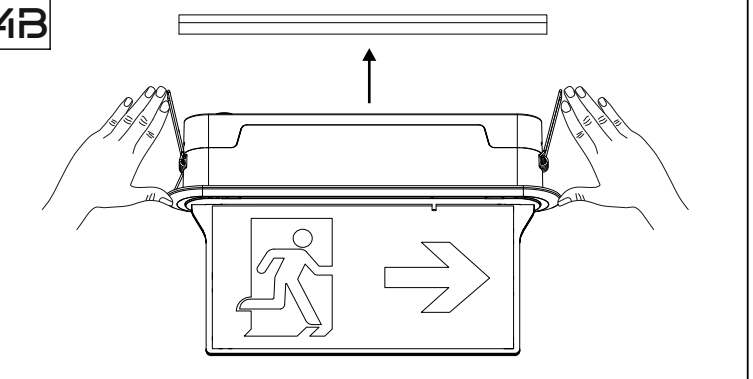
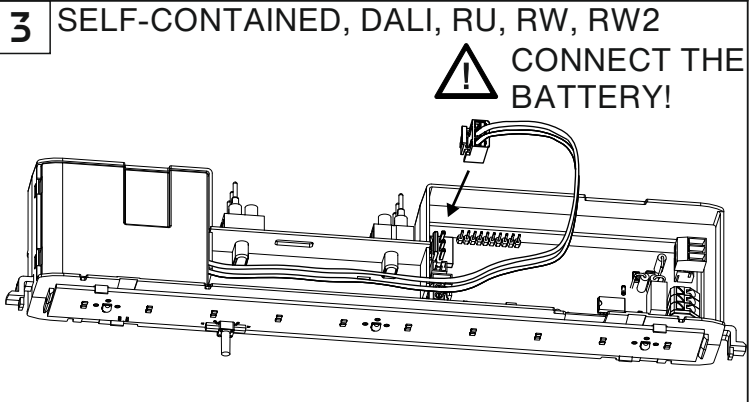
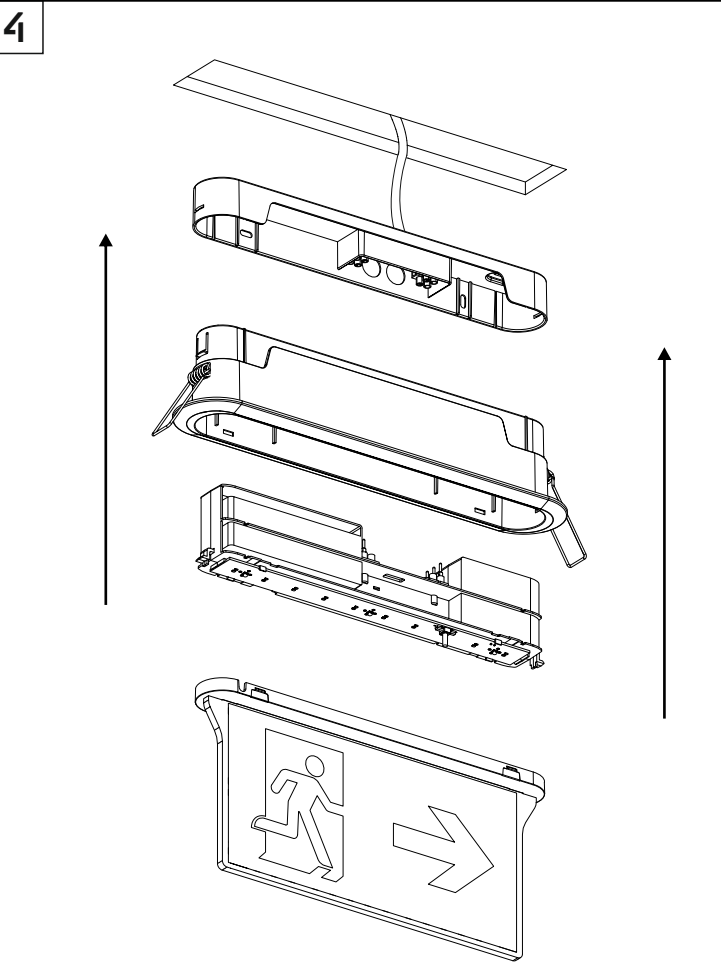
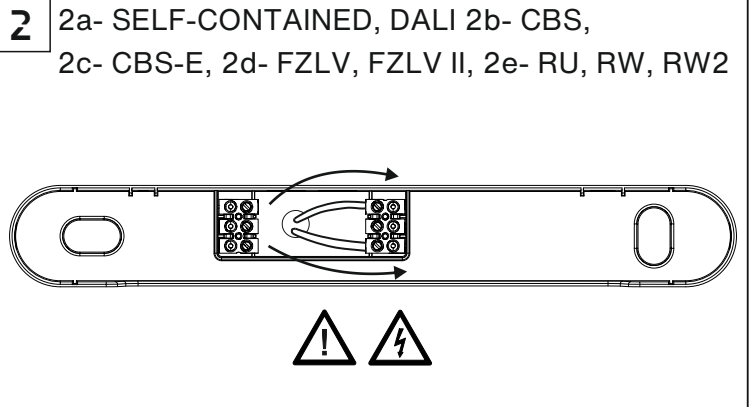
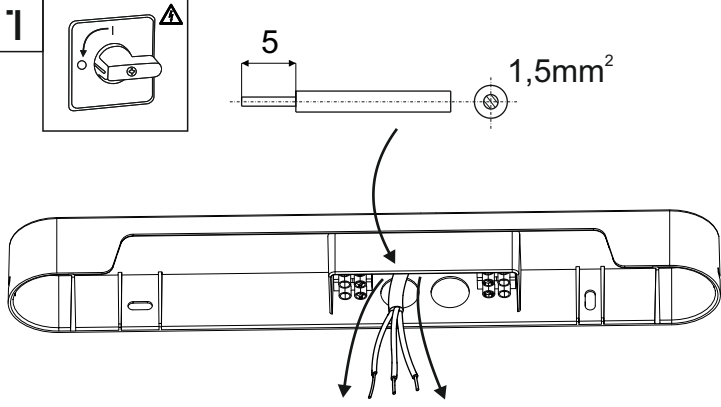

## 2a SELF-CONTAINED, DALI

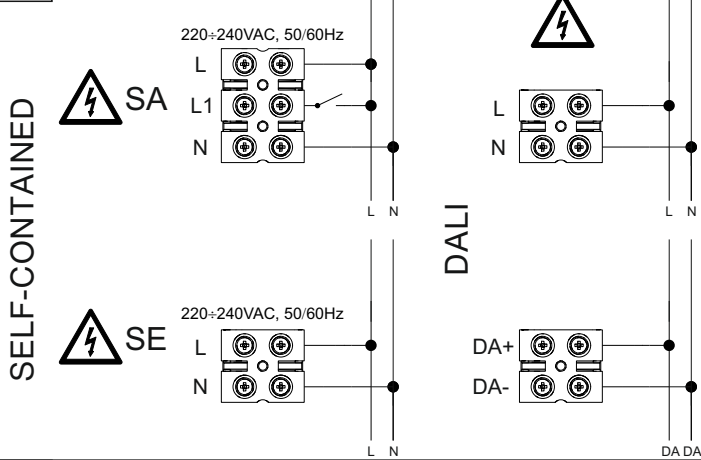

**CONNECT THE BATTERY**

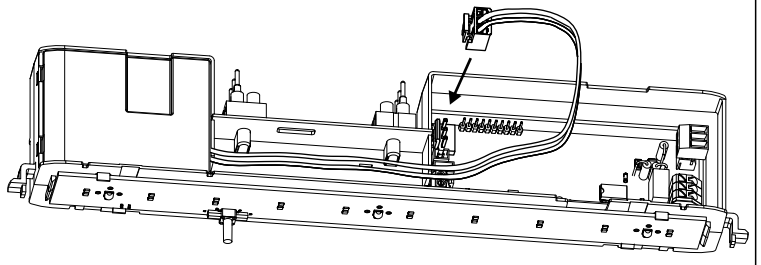

## 2B CBS

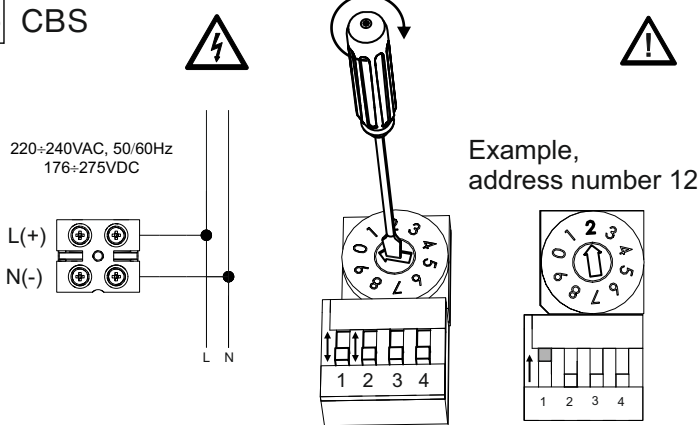

## 2C CBS-E

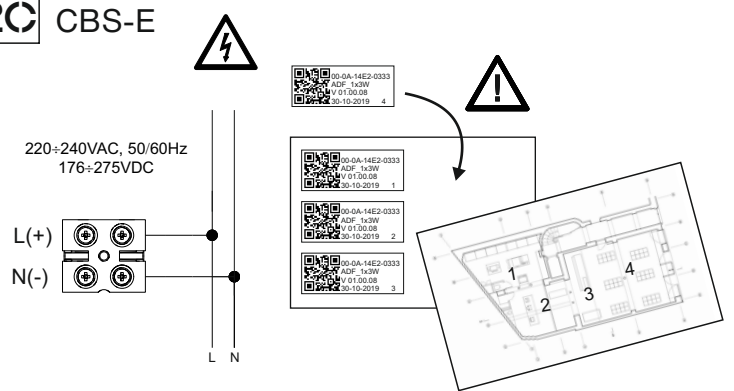

## 2D FZLV, FZLV II

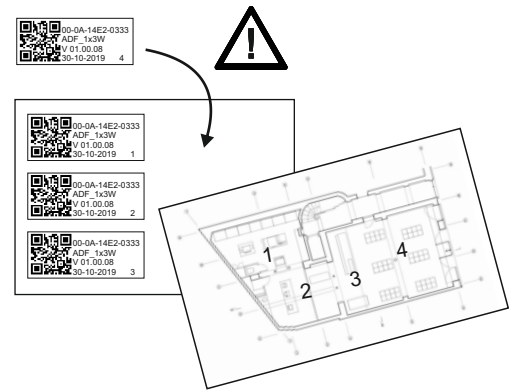
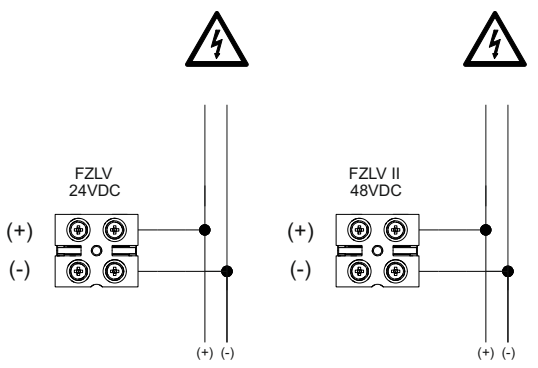

## 2E RU, RW, RW2

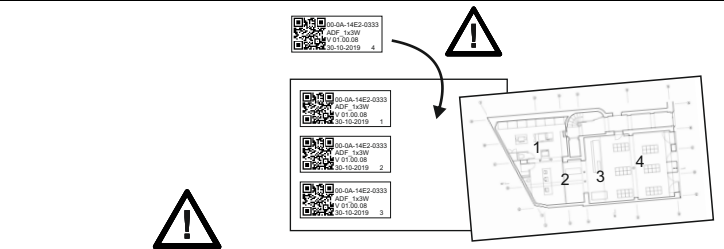
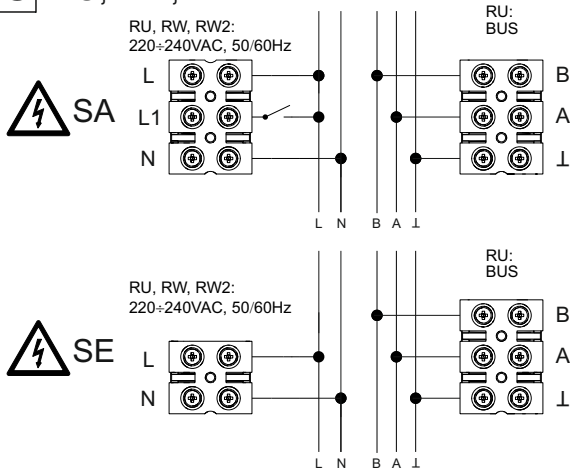

**CONNECT THE BATTERY**

